

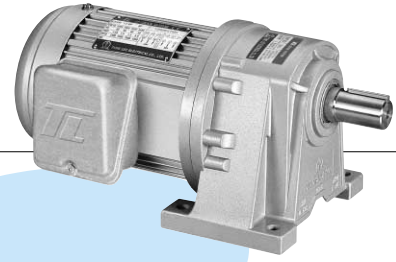

GEAR REDUCER
GEAR MOTOR



PL型(臥式)三相齒輪減速馬達

PL Type 3-Phase Horizontal Gear Reduction Motor

(Foot Mounted)

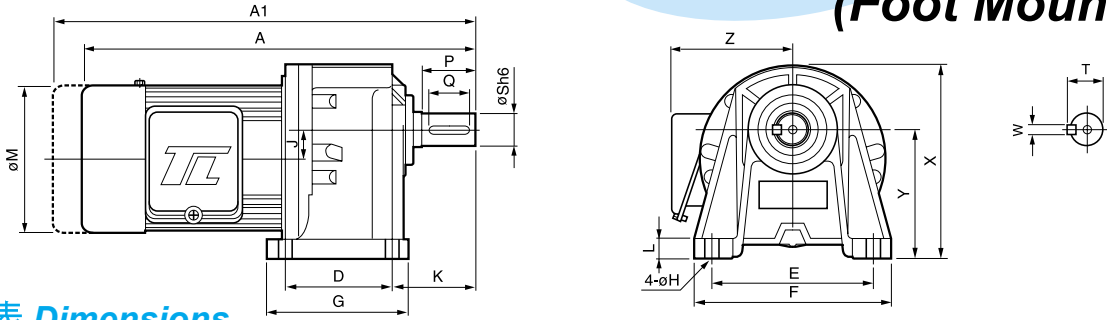

馬達尺寸表 Dimensions

馬力 HP	減速比 Gear Ratio	框號 Type	A	A1	D	E	F	G	H	L	J	K	M	X	Y	Z	出力軸端 Output Shaft					重量 App.Wt. Kg
																	P	Q	S	T	W	
0.1KW 1/8HPx4P	5~50	18	255	282	40	110	135	65	9	10	15.98	50	125	127	85	116	30	22	18	20	5	6.1
	60~200	22	287	314	65	130	155	90	11	12	17.66	60	125	145	90	116	40	30	22	25	7	7.0
	250~1800	22	356	383	65	130	155	90	11	12	17.66	60	125	145	90	116	40	30	22	25	7	8.9
	250~1800	28	393	420	90	140	170	120	11	17	39.1	70	125	170	110	100	45	35	28	31	7	11.6
0.2KW 1/4HPx4P	5~10	18	273	301	40	110	135	65	9	10	15.98	50	125	127	85	116	30	22	18	20	5	7.04
	12.5~25	18	273	301	40	110	135	65	9	10	15.98	50	125	127	85	116	30	22	18	20	5	7.1
	12.5~100	22	305	330	65	130	155	90	11	12	17.66	60	125	145	90	116	40	30	22	25	7	8.8
	120~200	28	334	361	90	140	170	120	11	17	23.11	70	125	170	110	100	45	35	28	31	7	12
	250~1800	28	411	437	90	140	170	120	11	17	23.11	70	125	170	110	100	45	35	28	31	7	12.4
250~1800	32	443	471	130	170	210	167	13	18	30.22	75	125	204	130	116	55	45	32	36.5	10	24.6	
0.4KW 1/2HPx4P	5~10	22	323	350	65	130	155	90	11	12	17.66	60	125	145	90	116	40	30	22	25	7	9.3
	12.5~25	22	323	350	65	130	155	90	11	12	17.66	60	125	145	90	116	40	30	22	25	7	10.6
	12.5~100	28	352	379	90	140	170	120	11	17	23.11	70	125	170	110	100	45	35	28	31	7	12.1
	120~200	32	382	409	130	170	210	167	13	18	30.22	75	125	204	130	116	55	45	32	36.5	10	25.2
	250~1800	32	464	491	130	170	210	167	13	18	30.22	75	125	204	130	116	55	45	32	36.5	10	27.6
250~1800	40	542	569	150	210	260	200	18	23	37.96	96	125	252	160	116	65	55	40	44	¹⁰ ₍₁₂₎	45.2	
0.75KW 1HPx4P	5~25	28	379	405	90	140	170	120	11	17	23.11	70	158	170	110	131	45	35	28	31	7	15.1
	30~100	32	409	470	130	170	210	167	13	18	30.22	75	158	204	130	131	55	45	32	36.5	10	22
	120~200	40	465	491	150	210	260	200	18	23	37.96	96	158	252	160	131	65	55	40	44	¹⁰ ₍₁₂₎	45.2
	250~1800	40	569	595	150	210	260	200	18	23	37.96	96	158	252	160	131	65	55	40	44	¹⁰ ₍₁₂₎	47.7
250~1800	50	580	606	160	230	285	210	18	25	39.2	104	158	293	176	-	75	65	50	53.5	14	60.5	
1.5KW 2HPx4P	5~30	32	442	477	130	170	210	167	13	18	30.22	75	190	204	130	138	55	45	32	36.5	10	25
	40~100	40	498	533	150	210	260	200	18	23	37.96	96	190	252	160	138	65	55	40	44	¹⁰ ₍₁₂₎	47.7
	120~200	50	509	543	160	230	285	210	18	25	39.2	104	190	293	176	-	75	65	50	53.5	14	55.0
2.2KW 3HPx4P	5~10	32	467	502	130	170	210	167	13	18	30.22	75	190	204	130	138	55	45	32	36.5	10	35.2
	15~60	40	523	558	150	210	260	200	18	23	37.96	96	190	252	160	138	65	55	40	44	¹⁰ ₍₁₂₎	49.1
3.7KW 5HPx4P	75~120	50	534	569	160	230	285	210	18	25	39.2	104	190	293	176	-	75	65	50	53.5	14	58.0
3.7KW 5HPx4P	5~20	40	552	586	150	210	260	200	18	23	37.96	96	230	252	160	190	65	55	40	44	¹⁰ ₍₁₂₎	67
	25~100	50	562	597	160	230	285	210	18	25	39.2	104	230	293	176	190	75	65	50	53.5	14	72

- A1之長度為馬達附剎車之總長。
- 淺藍色為輕扭力之機型。
- 1/8~1 HP之附剎車重量，約無剎車重量加 2 KG。
- 2~3 HP之附剎車重量約無剎車重量加 3.5 KG。
- 40~50 筒齒箱上附加 O 型吊環 (高度約 50 mm)。
- 軸徑40mm之鍵寬(w)標準為10mm，12mm為選用規格。

- Length of A1 is the total length of motor and the brake.
- Colour in Light blue indicates motor of smaller torque.
- Weight of 1/8 ~ 1HP motor w / brake shall be weight of motor w / 0 brake + 2Kg.
- Weight of a 2~3HP motor w / brake is equal to motor w/0 brake + 3.5kg.
- "O" type rings shall be attached to the 40 ~ 50mm gear box. (add. Height: 50mm).
- Keyway (w) for type 40 is 10mm, 12mm is optional.

以上數值若有變動，恕不另行通知 We reserve the right to change without further notice.