

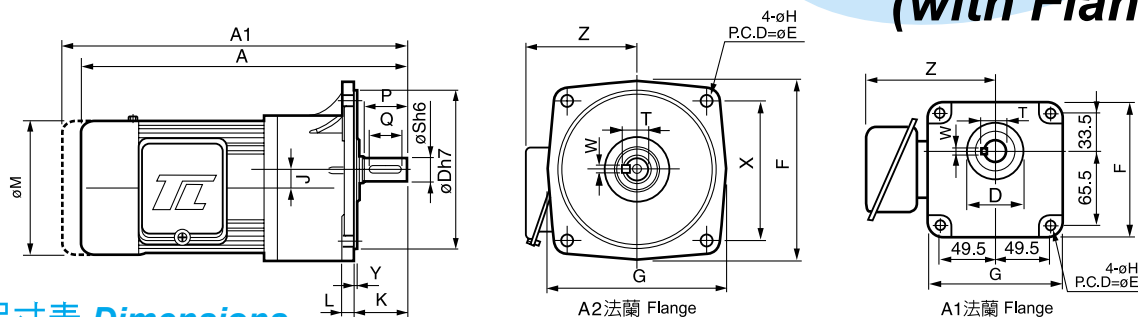

PF型(立式)三相齒輪減速馬達

PF Type 3-Phase Vertical Gear Reduction Motor (with Flange)



馬達尺寸表 Dimensions

馬力 HP	減速比 Gear Ratio	框號 Type	A	A1	D	E	X	F	G	H	L	J	K	M	Y	Z	出力軸端 Output Shaft					重量 App.Wt. Kg	備註 Remark
																	P	Q	S	T	W		
0.1KW 1/8HPx4P	5~50	18	255	282	50	140	99	122	120	9	12	15.98	40	125	5	116	30	22	18	20	5	6.08	A1法蘭
	60~200	22	287	314	148	185	131	168	165	11	12	17.66	50	125	3.5	116	40	30	22	25	7	7.3	A2法蘭
	250~1800	22	356	383	148	185	131	168	165	11	12	17.66	50	125	3.5	116	40	30	22	25	7	9.8	A2法蘭
	250~1800	28	393	420	170	220	156	205	195	$\begin{smallmatrix} \phi 11 \\ +14L \end{smallmatrix}$	13	23.11	60	125	4	116	45	35	28	31	7	11.9	A2法蘭
0.2KW 1/4HPx4P	5~10	18	273	302	50	140	99	122	120	9	12	15.98	40	125	5	116	30	22	18	20	5	7.1	A1法蘭
	12.5~25	18	273	302	50	140	99	122	120	9	12	15.98	40	125	5	116	30	22	18	20	5	7.13	A1法蘭
	12.5~100	22	305	330	148	185	131	168	165	11	12	17.66	50	125	3.5	116	40	30	22	25	7	8.81	A2法蘭
	120~200	28	334	361	170	220	156	205	195	$\begin{smallmatrix} \phi 11 \\ +14L \end{smallmatrix}$	13	23.11	60	125	4	116	45	35	28	31	7	11.7	A2法蘭
	250~1800	28	411	437	170	220	156	205	195	$\begin{smallmatrix} \phi 11 \\ +14L \end{smallmatrix}$	13	23.11	60	125	4	116	45	35	28	31	7	12.8	A2法蘭
0.4KW 1/2HPx4P	250~1800	32	443	471	185	255	180	241	225	15	15	30.22	70	125	4	116	55	40	32	36.5	10	25.2	A2法蘭
	5~10	22	325	350	148	185	131	168	165	11	12	17.66	50	125	3.5	116	40	30	22	25	7	9.62	A2法蘭
	12.5~25	22	325	350	148	185	131	168	165	11	12	17.66	50	125	3.5	116	40	30	22	25	7	11	A2法蘭
	12.5~100	28	352	380	170	220	156	205	195	$\begin{smallmatrix} \phi 11 \\ +14L \end{smallmatrix}$	13	23.11	60	125	4	116	45	35	28	31	7	13.4	A2法蘭
	120~200	32	385	410	185	255	180	241	225	15	15	30.22	70	125	4	116	55	45	32	36.5	10	24.4	A2法蘭
0.75KW 1HPx4P	250~1800	32	465	592	185	255	180	241	225	15	15	30.22	70	125	4	116	55	45	32	36.5	10	26.8	A2法蘭
	250~1800	40	545	570	230	310	219	297	268	15	20	37.96	76	125	5	116	65	55	40	44	$\begin{smallmatrix} 10 \\ (12) \end{smallmatrix}$	45.6	A2法蘭
	5~25	28	380	405	170	220	156	205	195	$\begin{smallmatrix} \phi 11 \\ +14L \end{smallmatrix}$	13	23.11	60	158	4	131	45	35	28	31	7	15.1	A2法蘭
	30~100	32	410	435	185	255	180	241	225	15	15	30.22	70	158	4	131	55	45	32	36.5	10	26.9	A2法蘭
1.5KW 2HPx4P	120~200	40	465	492	230	310	219	297	268	15	20	37.96	76	158	5	131	55	45	32	36.5	10	45.6	A2法蘭
	250~1800	40	570	595	230	310	219	297	268	15	20	37.96	76	158	5	131	65	55	40	44	$\begin{smallmatrix} 10 \\ (12) \end{smallmatrix}$	48.1	A2法蘭
	250~1800	50	580	606	250	352	249	320	290	18	22	39.2	86	158	5	131	75	65	50	53.5	14	57.3	A2法蘭
2.2KW 3HPx4P	5~30	32	442	478	185	255	180	241	225	15	15	30.22	70	190	4	138	55	45	32	36.5	10	26.5	A2法蘭
	40~100	40	500	535	230	310	219	297	268	15	20	37.96	76	190	5	138	65	55	40	44	$\begin{smallmatrix} 10 \\ (12) \end{smallmatrix}$	49.3	A2法蘭
	120~200	50	510	543	250	352	249	320	290	18	22	39.2	86	190	5	138	75	65	50	53.5	14	60.2	A2法蘭
3.7KW 5HPx4P	5~10	32	467	502	185	255	180	241	225	15	15	30.22	70	190	4	138	55	45	32	36.5	10	34.2	A2法蘭
	15~60	40	525	560	230	310	219	297	268	15	20	37.96	76	190	5	138	65	55	40	44	$\begin{smallmatrix} 10 \\ (12) \end{smallmatrix}$	50.8	A2法蘭
3.7KW 5HPx4P	75~120	50	535	570	250	352	249	320	290	18	22	39.2	86	190	5	138	75	65	50	53.5	14	55.6	A2法蘭
	5~20	40	552	586	230	310	219	297	268	15	20	37.96	82	230	5	190	65	55	40	44	$\begin{smallmatrix} 10 \\ (12) \end{smallmatrix}$	56.5	A2法蘭
25~100	50	565	600	250	352	249	320	290	18	22	39.2	86	230	5	190	75	65	50	53.5	14	60.0	A2法蘭	

- A1之長度為馬達附剎車之總長。
 - 淺藍色為輕扭力之機型
 - 1/8~1 HP 之附剎車重量, 約無剎車重量加2KG.
 - 2~3 HP 之附剎車重量, 約無剎車重量加 3.5 KG.
 - 軸徑40mm之鍵寬(w)標準為10mm, 12mm為選用規格.
 - Length of A1 is the total length of motor and the brake.
 - Colour in Light blue indicates motor of smaller torque.
 - Weight of 1/8 ~ 1HP motor w / brake shall be weight of motor w / 0 brake + 2Kg.
 - Weight of a 2~3HP motor w / brake is equal to motor w/0 brake + 3.5kg.
 - Keyway (w) for type 40 is 10mm, 12mm is optional.
- *以上數值若有變動, 恕不另行通知* We reserve the right to change without further notice.